

GENERAL NOTES:

1. Material:

- a. Extruded aluminum alloy 6063-T6 with a minimum wall thickness of 1/8".

2. Finishes:

- a. Available in anodized, kynar painted and powder coat paint finishes

3. Doors:

- a. Standard door thickness is 2".
- b. Available stile widths: 2-1/2", 3-1/2" and 4-1/2".
- c. Available top rail heights: 2-1/2", 3-1/2" and 5".
- d. Available bottom rail heights: 6" and 10" or greater using dress plates (10" recommended to comply with 2004 ADA guidelines).
- e. Center rail minimum is 1-1/2" (per detail 8 on page 6).
- f. Interior side glass stops snap on to accommodate most glass thickness (special glass sizes can be accommodated, see page 12 or consult factory).

4. Frames:

- a. See details following for 3" x 6" profile.
- b. Optional 3" x 5" Profile available (the 1" reduction is taken off the pull side), see details 1A, 7A, 13A & 19A on Page 9.
- c. Optional 1 1/8" high sub-header available, See detail 31B on page 11.
- d. Glass thickness may vary as desired. See details on page 12.
- e. Glass location may vary as desired. See detail 4 on page 5, and 18 on page 7.*

5. Door & Frame: For multi-light/true divided construction (C-2), intermediate vertical and horizontal muntins (1/2" minimum), see page 12 and details 14 & 17 on page 7, and 20 & 23 on page 8.

6. Threshold and floorbox types: see details on page 14 & 16.

7. Door in open position and door projection: see detail 26 on page 13 and detail 33 on page 15.

8. Grilles available, consult factory.

9. Further information: Refer to specifications following, miscellaneous items section M, curtainwall applications section L, or consult the factory.

Exposed Shafts / Header / Applied Glass Stops (C-3)

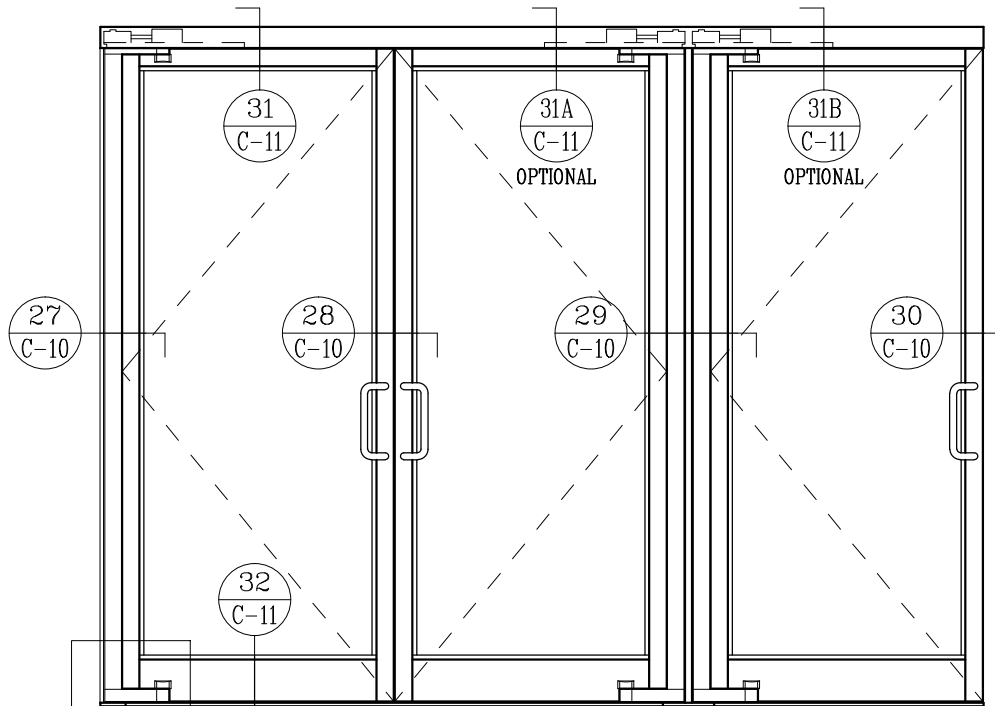
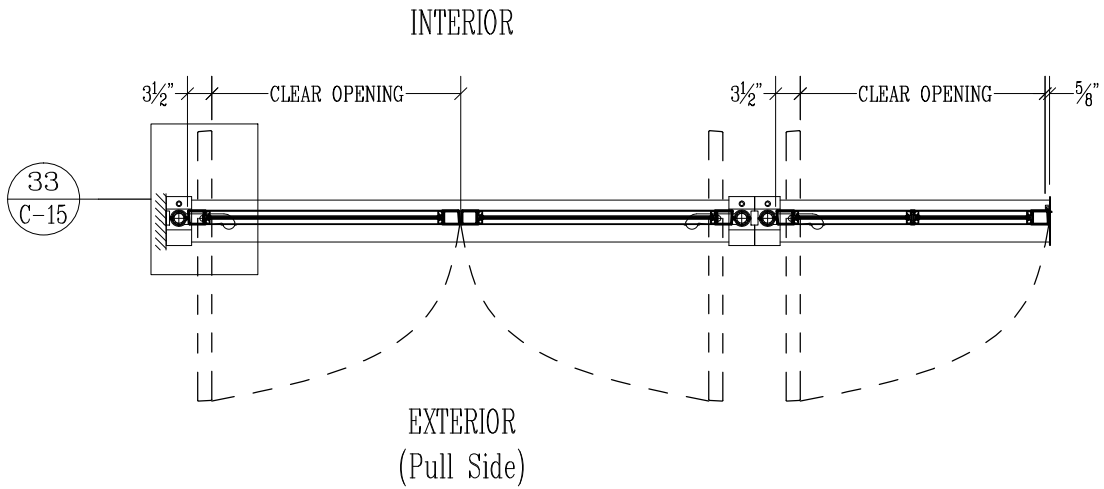

SEE PAGE #16 FOR SIMILAR FLOORBOX DETAILS
(WITH AND WITHOUT THRESHOLD)

Exposed Shafts / Header / Applied Glass Stops (C-3)

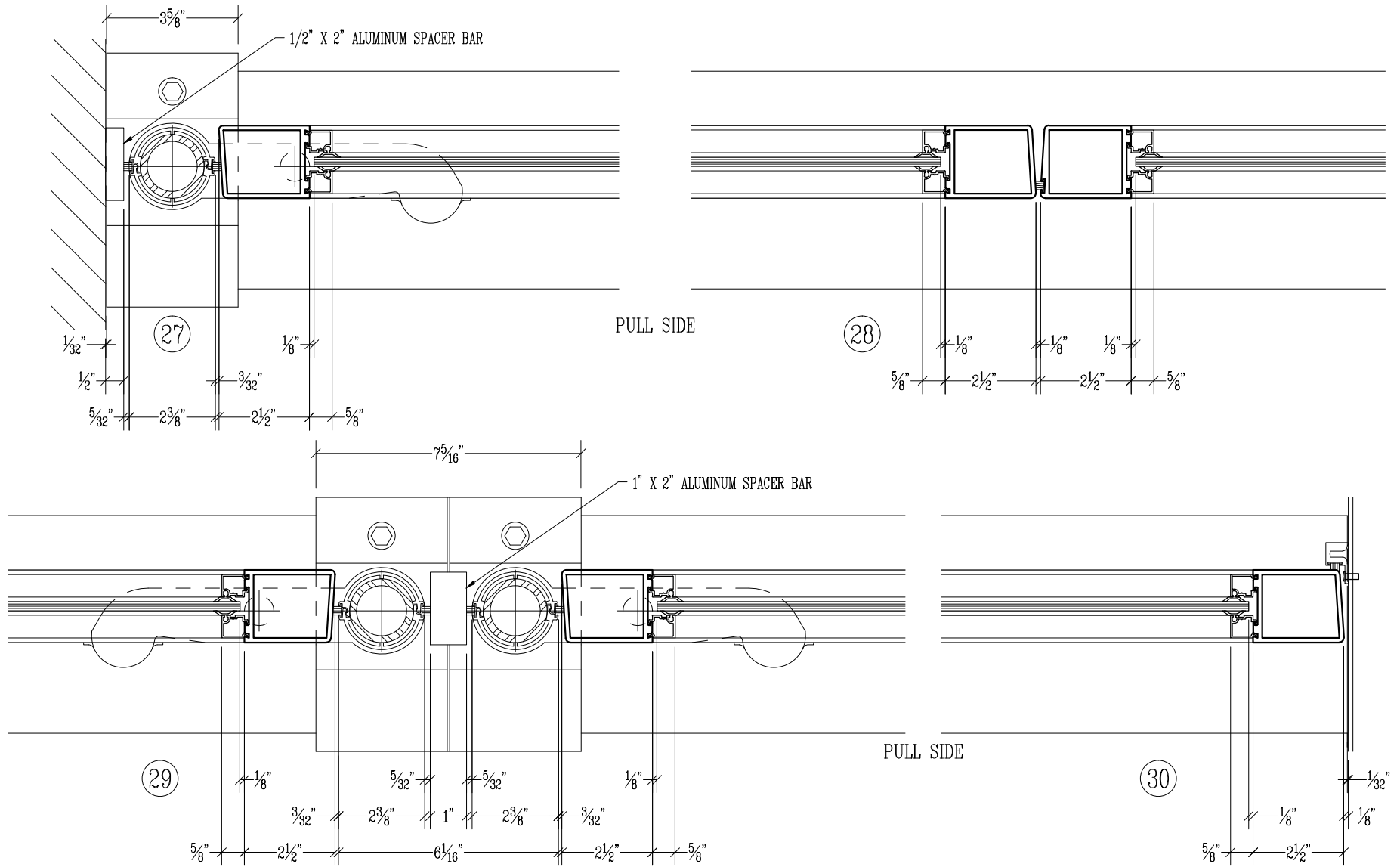

Exposed Shafts / Header / Applied Glass Stops (C-3)

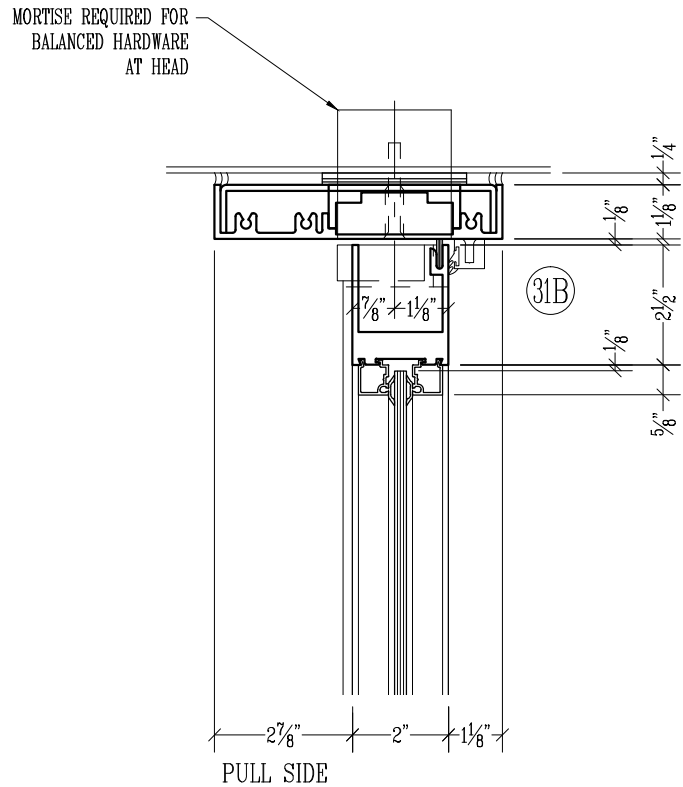
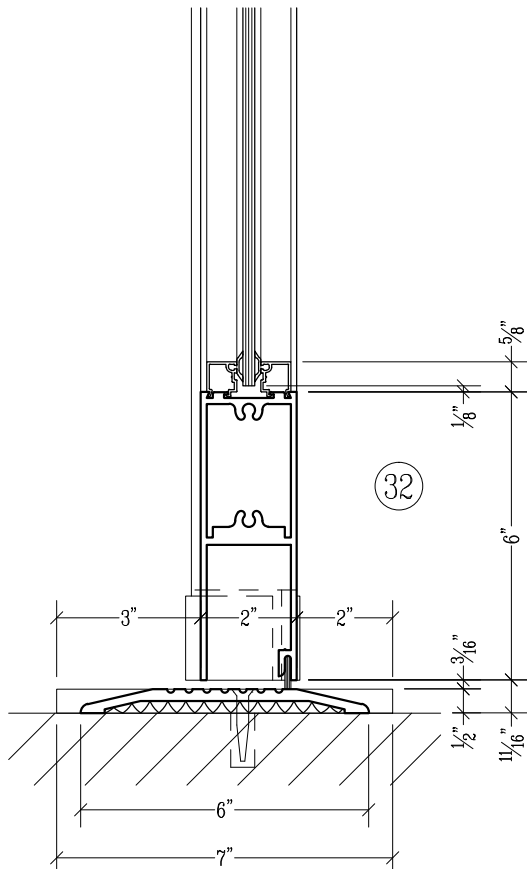
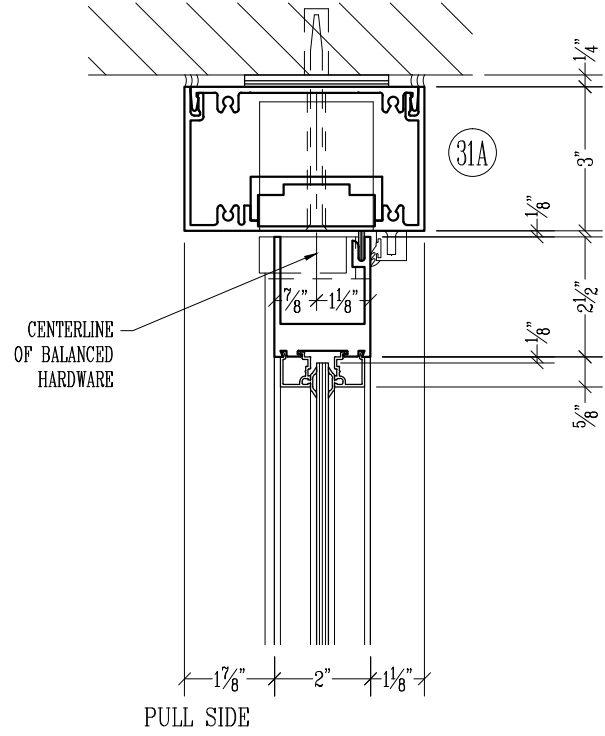
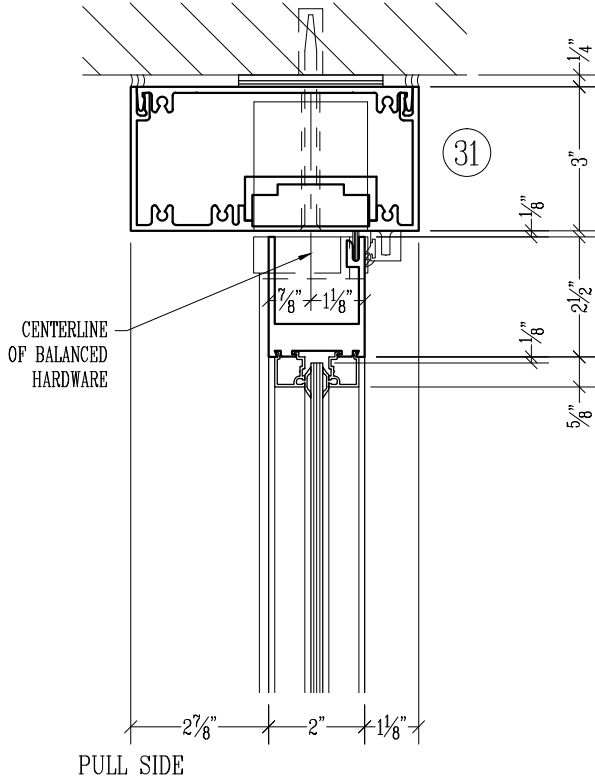

SCALE: 1/4" = 1"

EXTRUDED ALUMINUM GLASS STOPS FOR DOORS AND FRAMES.
(consult factory for special glass thickness)

Door Glass

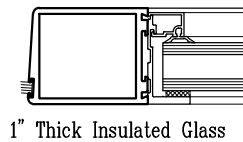
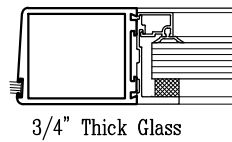
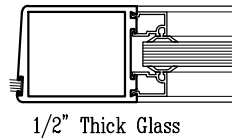
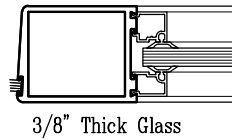
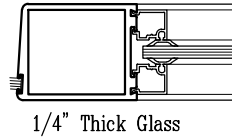

Frame Glass

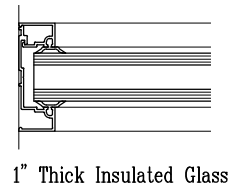
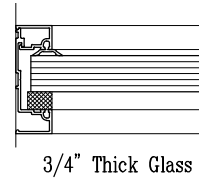
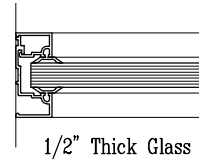
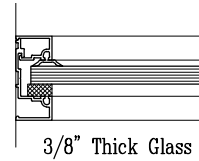
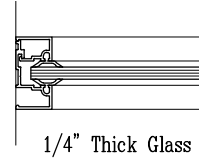

EXTRUDED ALUMINUM MID-RAILS FOR DOORS (1/4" GLASS SHOWN).

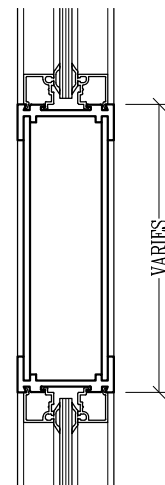
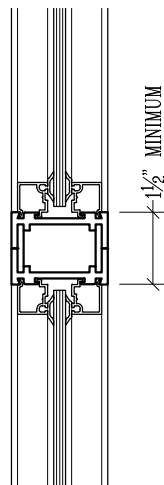
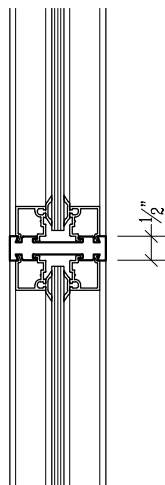

Exposed Shafts (C-3)

NOTES:

1. Balanced hardware arm and door shown dotted, in the open position ("A" arm size shown).

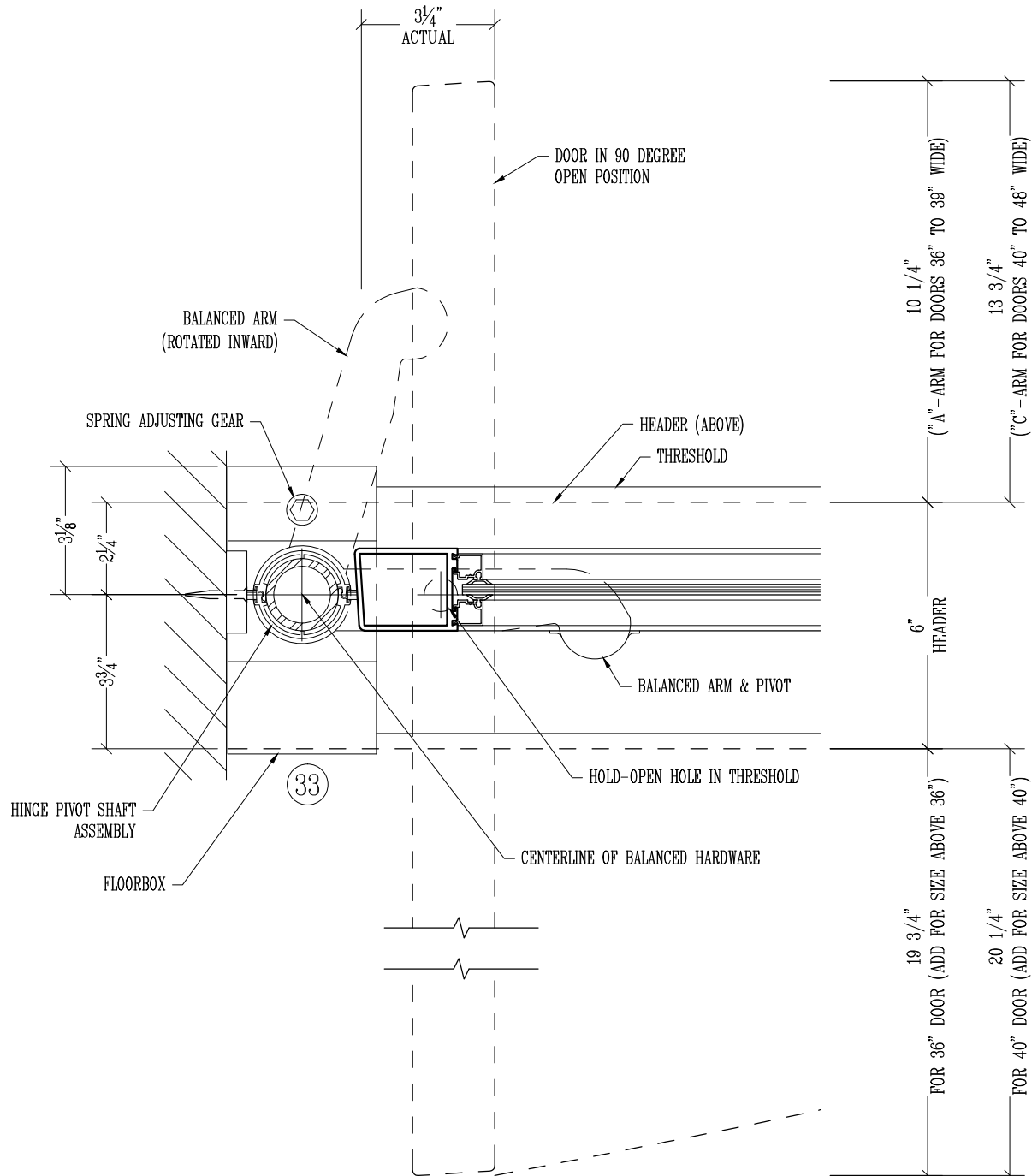

Exposed Shafts (C-3)

TYPICAL FLOORBOX LAYOUT AT HINGE JAMB.

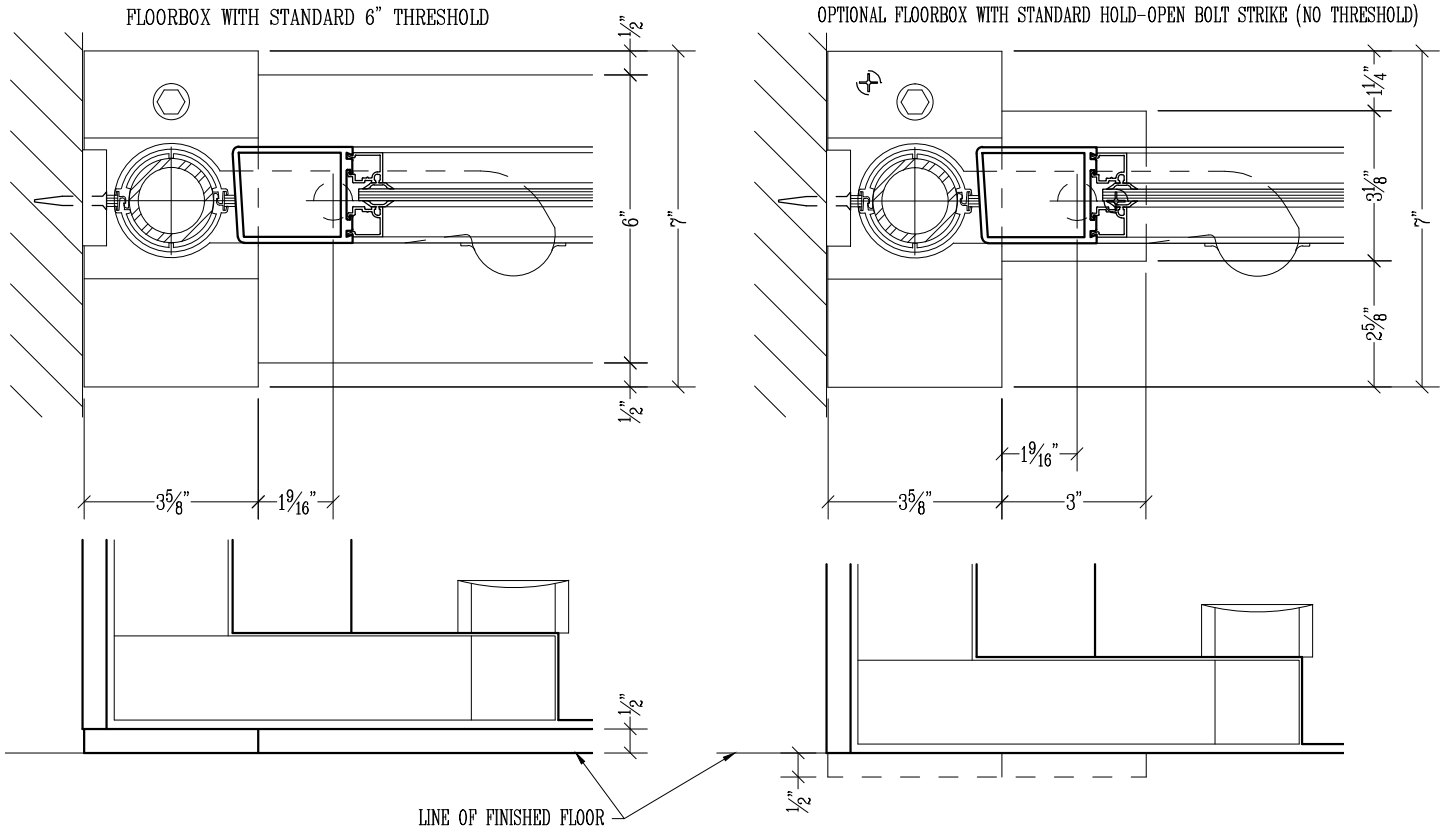

AVAILABLE THRESHOLD OPTIONS:

- 1/2" x 6" Extruded thresholds are available in Aluminum (A), Bronze (B) and Nickel Silver (NS).
- 1/2" x 6" Formed-up stainless steel or bronze saddle type threshold shown (formed-up type can be made in different sizes & profiles consult factory).

