

GENERAL DRAWING NOTES:

1. Material:

- a. Standard for Stainless Steel is Alloy Number 304 with a minimum wall thickness of 3/32" (.09").
- b. Optional for Stainless Steel is Alloy Number 316 (more corrosion resistant) with a minimum wall thickness of 3/32" (.09").

2. Finishes:

- a. Available in Polished, Satin, Non-Directional (Jitterbug) & Bead Blasted finishes.

3. Doors:

- a. Standard door thickness is 2".
- b. Available stile width: 1 5/32" minimum.
- c. Available top rail heights: 4-3/4" minimum.
- d. Available bottom rail heights: 4 3/4" minimum (10" recommended to comply with 2004 ADA guidelines).

4. Frames:

- a. See details following for 3" x 6" nominal profile.
- b. Optional 3" x 5" nominal Profile available (the 1" reduction is taken off the pull side), see details 1A, 7A, 12A & 17A on Page 10.
- c. Optional 1 1/8" x 6" (or 5") nominal Profile header available, see detail 27B on Page 12.
Note: mortise is required at surrounding material for balanced hardware.
- d. Glass thickness may vary as desired. See details on page 14.
- e. Glass location may vary as desired. See detail 4 on page 6, and 16 on page 8.*
- f. For multi-light/true divided construction (H-2), intermediate vertical and horizontal muntins (1/4 x 2" minimum) see details 15 on page 8 and 20 on page 9.

5. Threshold and floorbox types: see details on pages 16 & 18.

6. Door in open position and door projection: see detail 22 on page 15 and detail 33 on page 17.

7. Further information: Refer to specifications following, miscellaneous items section M, curtainwall applications section L, or consult the factory.

Exposed Shafts / Header (H-3)

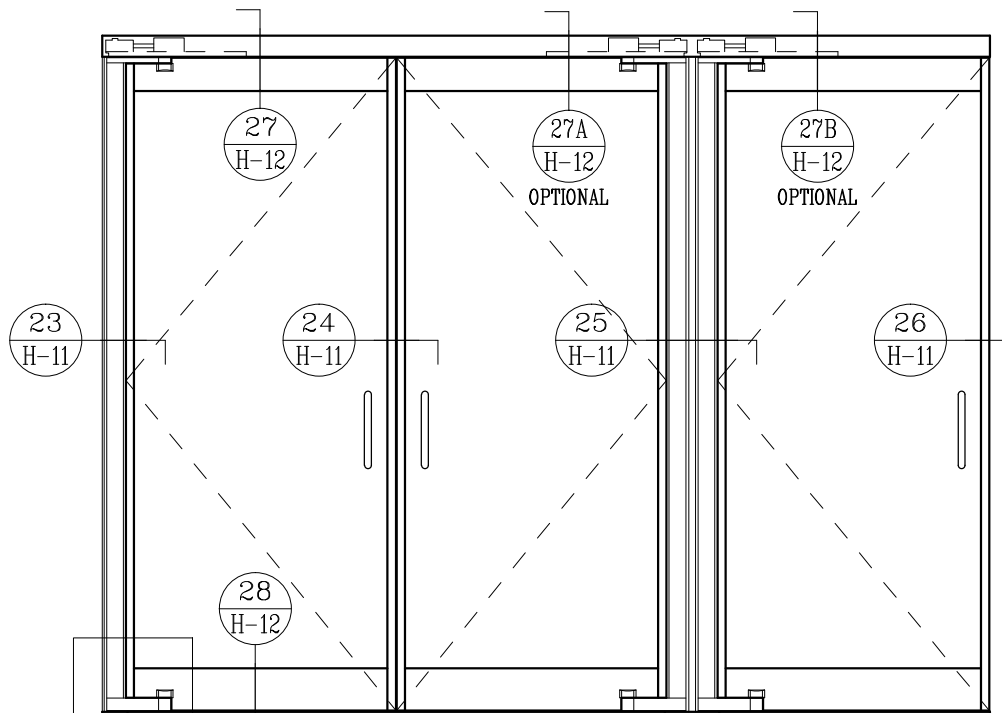
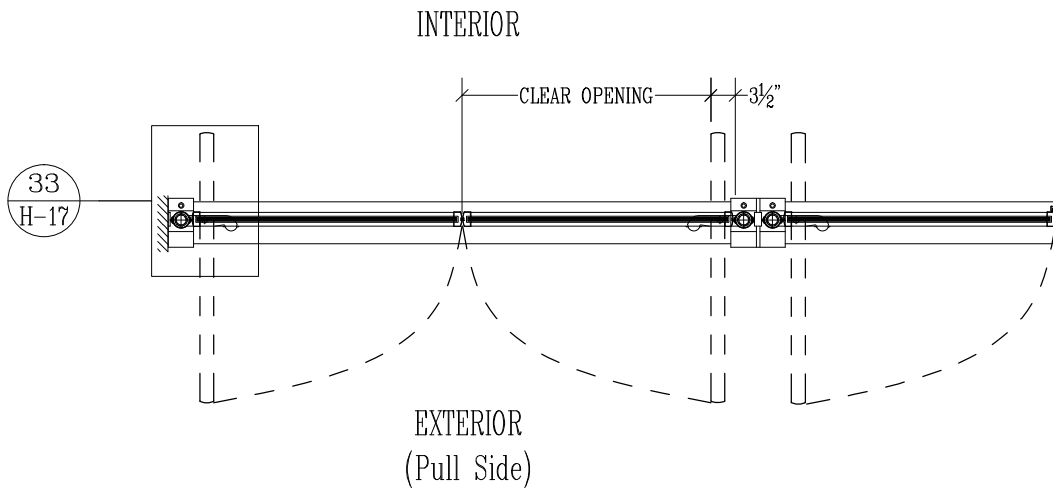

SEE PAGE #18 FOR FLOORBOX DETAILS
(WITH AND WITHOUT THRESHOLD)

Exposed Shafts / Header (H-3 & 4)

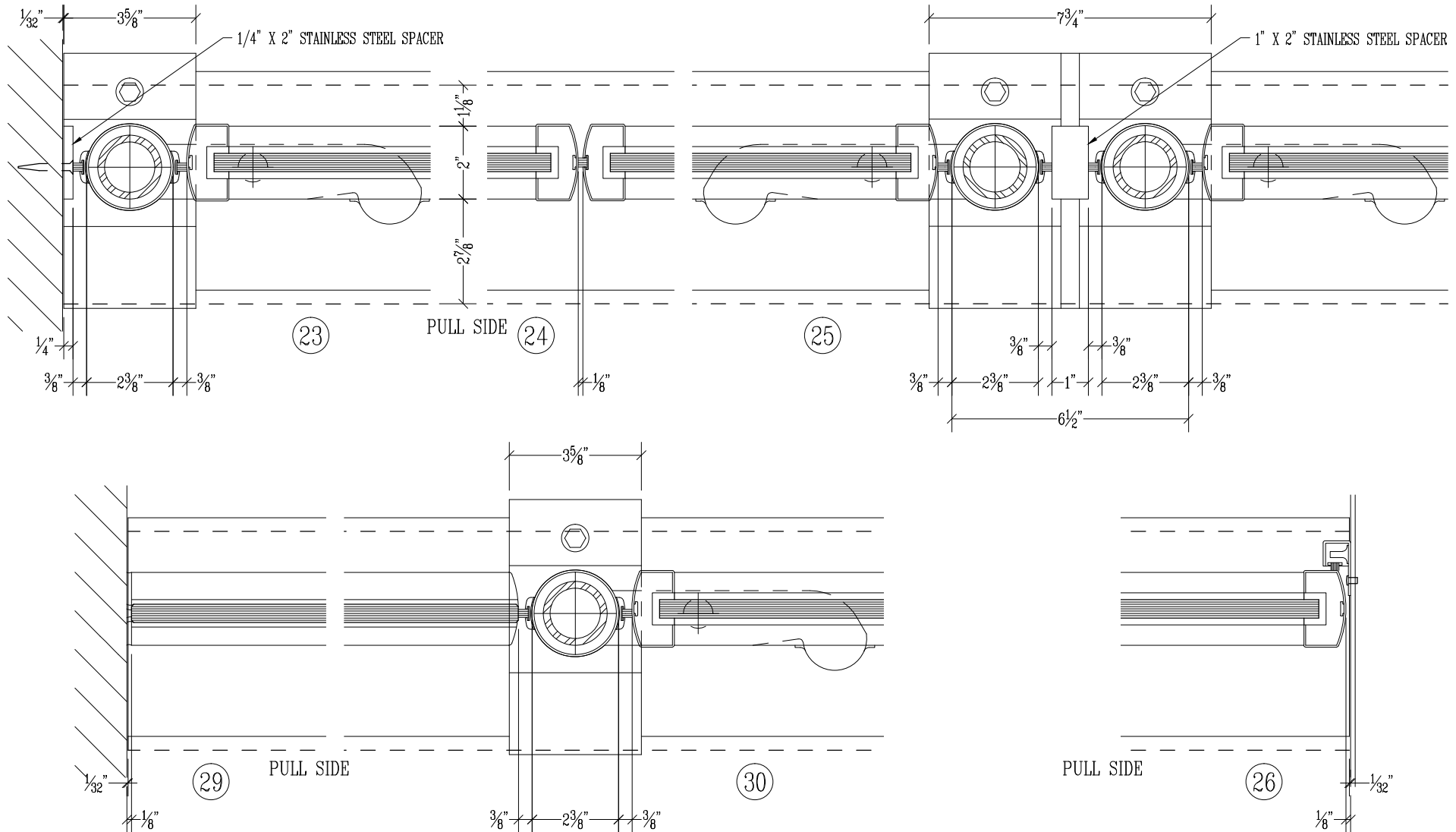

Exposed Shafts / Optional Header Framing (H-3 & 4)

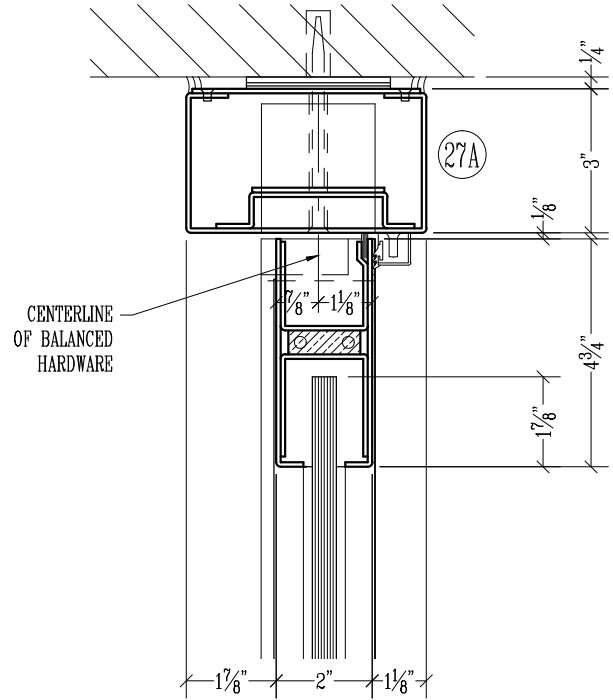
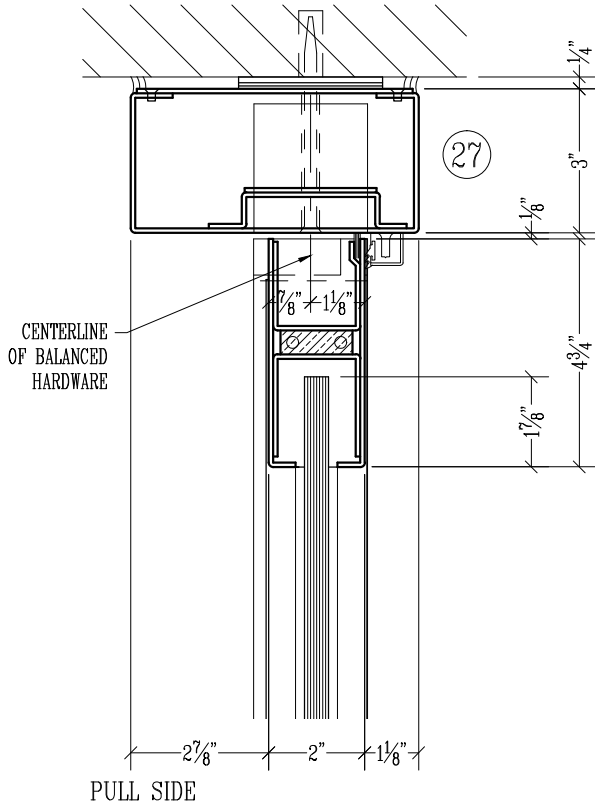

MORTISE REQUIRED FOR
BALANCED HARDWARE
AT HEAD

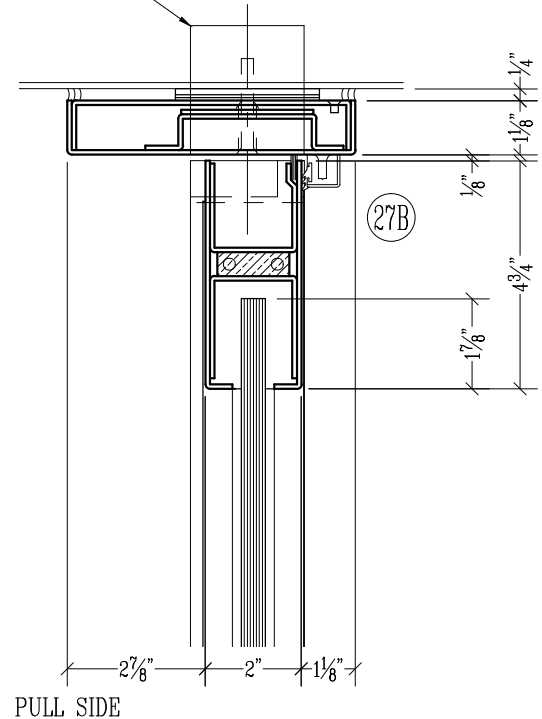
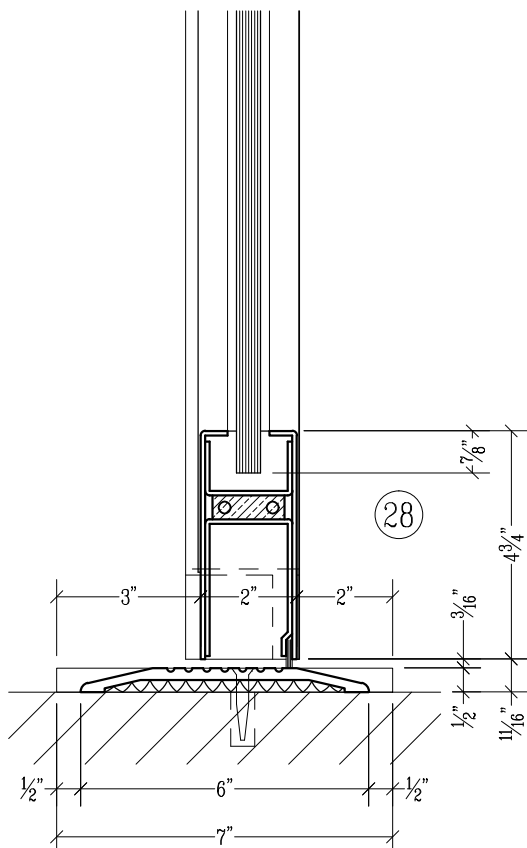

SCALE: 1/4" = 1"

Exposed Shafts (H-3 & 4)

NOTES:

1. Balanced hardware arm and door shown dotted, in the open position ("A arm size shown).

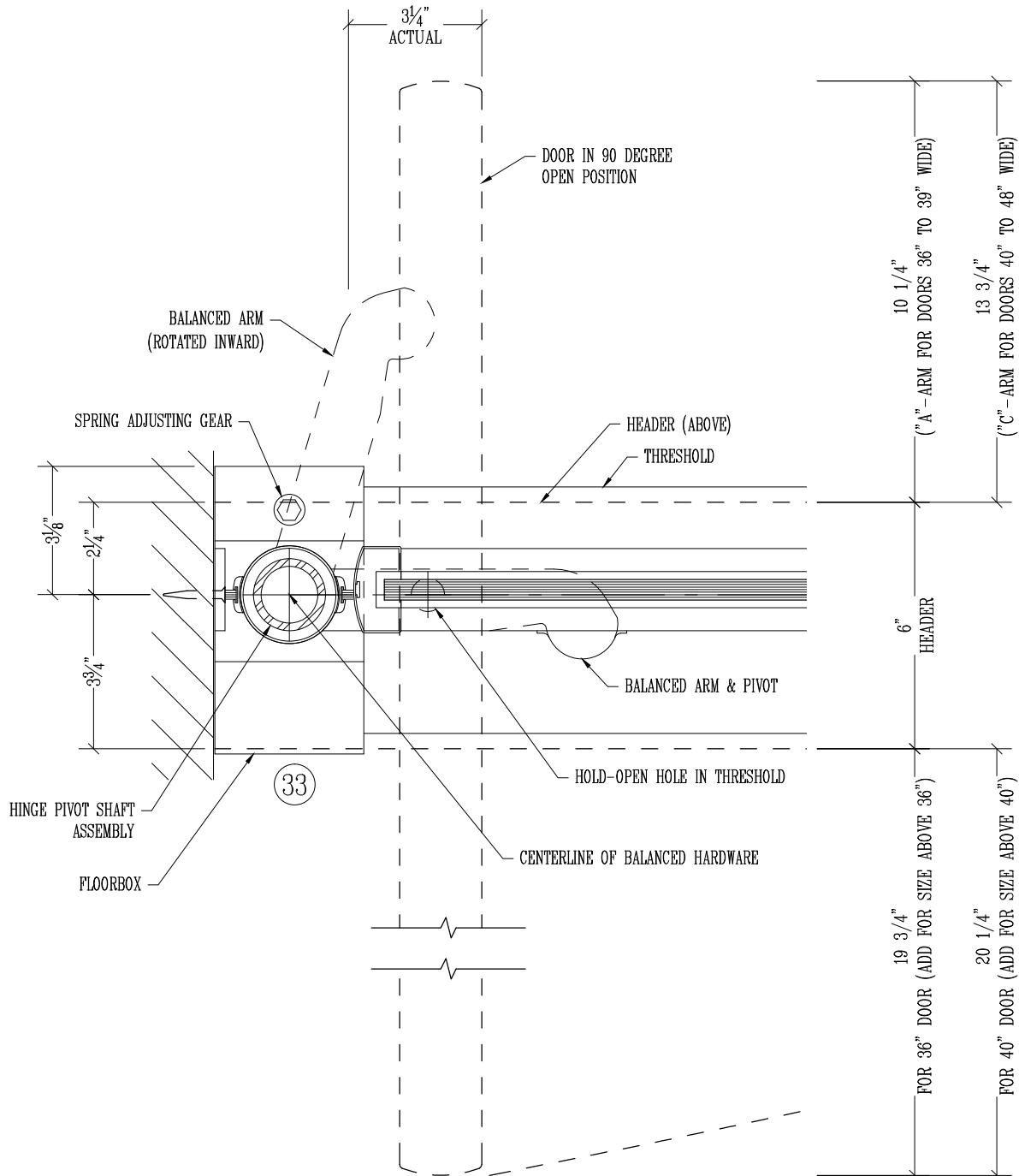

Exposed Shafts (H-3 & 4)

TYPICAL FLOORBOX LAYOUT AT HINGE JAMB.

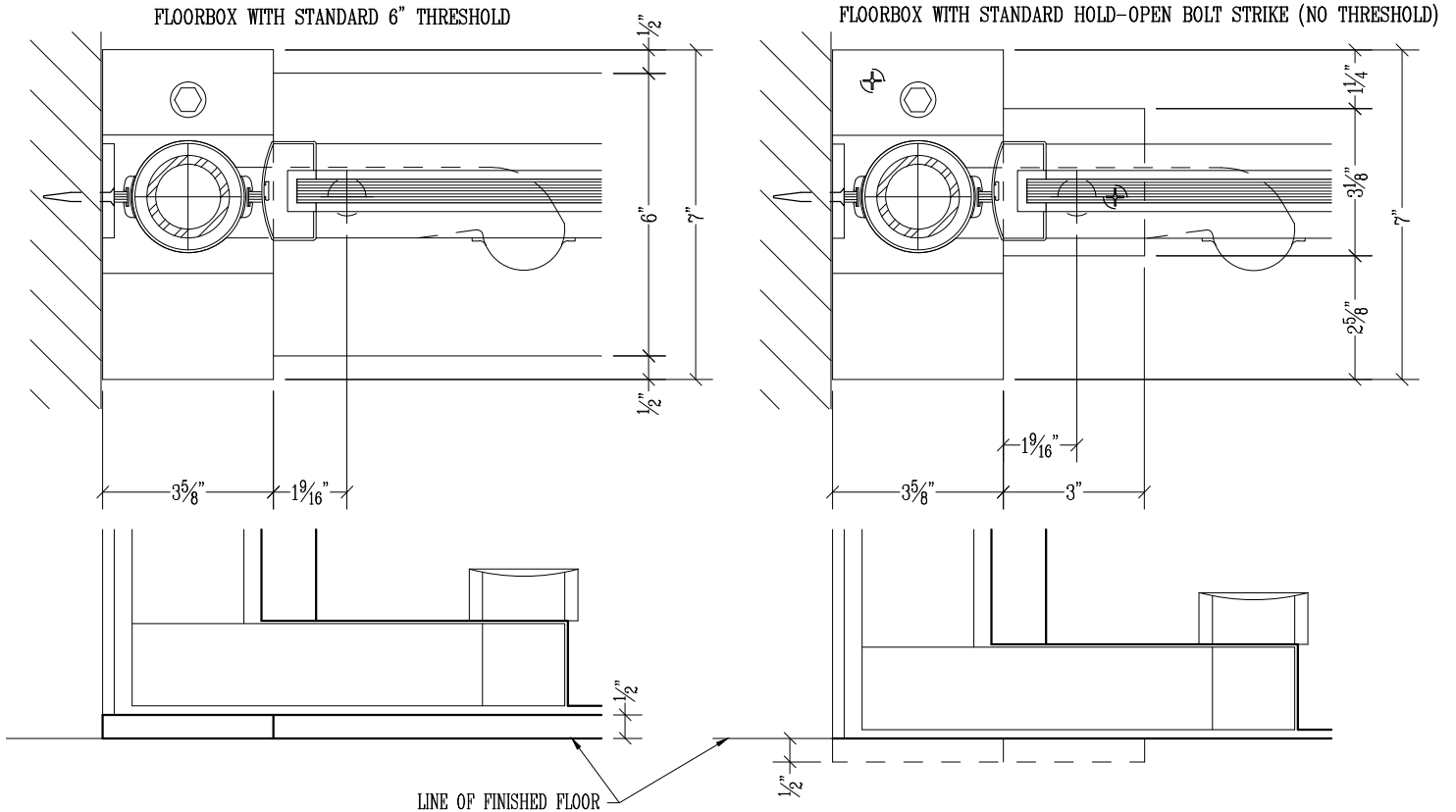

AVAILABLE THRESHOLD OPTIONS:

1. 1/2" x 6" Extruded thresholds are available in Aluminum (A), Bronze (B) and Nickel Silver (NS).
2. 1/2" x 6" Formed-up stainless steel or bronze saddle type threshold shown (formed-up type can be made in different sizes & profiles consult factory).

